

LiftBox for 65" / 70" LED LCDs

The TRIUMPH BOARD LiftBox for LED LCDs is the perfect and easy solution to move TRIUMPH BOARD LED LCDs up and down, without electric power.

The partially overlapping weight range give the installer the option of 400 mm lift.

All LiftBox models offer a wide range of accessories and come in a compact and stylish white design that is hidden behind the screen.

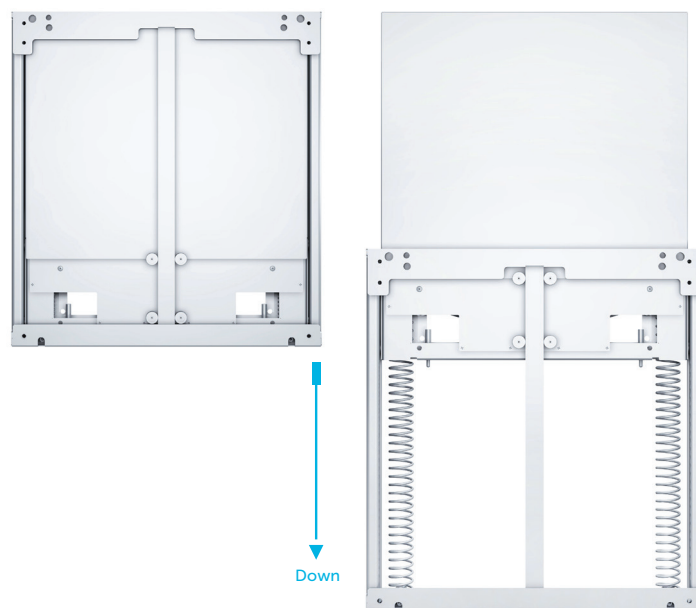

Features

- Ergonomic and easy to use
- Quality product, safe to use
- Compact design - product disappears behind the screen
- Long product lifetime
- Fast and easy installation, maintenance-free
- Low transport and installation cost.

Specification

EAN:	8592580082801
Model:	TRIUMPH BOARD Lift Box for 65" / 70" LED LCD
Designed for:	65" / 70" MULTI Touch LED LCD
Material:	Steel frame, stainless steel wall frame cover painted white
Net Weight:	22 kg
Net Stand Dimensions:	558 x 600 x 74mm
Gross Stand Weight:	22,5 kg
Packing:	610 x 655 x 95 mm
Lift:	400 mm / 15.75"
Max. load:	95 kg

Accessories

EAN:	8592580082511
Model:	Flatscreen/Vesa Interface for Lift Box for 55"/65" / 70" LED LCD
Designed for:	55"/65" / 70" MULTI Touch LED LCD
Material:	White sheet steel frame
Net Weight:	4,2 kg
Dimensions:	860 x 599 x 30 mm
Gross Weight:	4,6 kg
Packing:	945 x 135 x 45 mm
Max. load:	95 kg

