

User Manual v 1.3

May 2014

TRIUMPH BOARD Mobile Stand with Electric Lift for LED LCD's



CONTENT

1) Product Description	4
2) Technical specification	5
3) Package Content.....	6
4) Installation.....	6
4.1) Lift column installation.....	7
4.2) Mounting head installation	7
4.3) Power supply installation	8
4.4) Screen installation	9
4.5) Pen tray Installation (Optional).....	10
4.6) Laptop tray installation (Optional)	11
4.7) Put back cover on and secure using screws.	12
5) Repair Service and Contacts	13

DECLARATION OF CONFORMITY

We TRIUMPH BOARD a.s., Neklanova 122/15, 128 00 Praha 2

Declare under sole responsibility that the product:

TRIUMPH BOARD Mobile Stand with Electric Lift for LED LCD's

Model: Mobile Stand with Electric Lift for LED LCD's

EAN: 8592580082405

Is in conformity of essential requirements of EU directives:

EU Standards
Machine 89/392/EEG with 91/368/EEG and 93/44/E
EMC 89/336/EEG with EN 55014 and EN 55'
Low voltage 73/23/EEC with EN 60335/1

In the configuration tested, the EUT complied with the standards specified above.

Place of Issue: Prague

Datum of issue: 11th April 2013



Ing. Ondřej Kryšpín, Chairman of the Board of Directors

Note: Translation from original CE

1) Product Description

TRIUMPH BOARD Mobile Stand with Electric Lift for 55“, 65“, 70“ and 84“ MULTI Touch LED LCD is equipped with an electric lift that allows for positioning of height within a range of 675 mm.

For the easy addition of LED LCD, the TRIUMPH BOARD Mobile Stand with Electric Lift for LED LCD's is equipped with an assembly hitch corresponding to the VESA standard. For movement, the Stand is equipped with wheels which, if necessary, can be easily blocked to prevent unwanted movements of the Stand.

TRIUMPH BOARD Mobile Stand with Electric Lift for LED LCD's is designed to provide a high level of comfort as well as the quiet and smooth attachment of LED LCD for the entire period of the product's lifespan. Pen Tray and Laptop Tray are optional parts of the Stand.

IMPORTANT – under no circumstances should children or anyone else climb onto or hang on the stand under any circumstances as the unit could fall over and cause serious injury!



2) Technical specification

EAN:	8592580082405
Model:	TRIUMPH BOARD Mobile Stand with Electric Lift for LED LCD's
Designed for:	Interactive TRIUMPH BOARD 55, 65, 70" MULTI Touch LED LCD
Stand material:	steel
Assembly:	VESA 400x200, 600x400, 600x200, 300x300, 400x400, 600x600
Lift of Stand:	675 mm
Centre of LED LCD monitor at highest position:	1735 mm
Centre of LED LCD monitor at lowest position:	1060 mm
Maximum Load:	130 kg
Control unit:	Panel with connectors, switch, IEC C22, cable intake
Power source:	110-120 VAC, 60 Hz
Dimensions without packaging:	1385 x 688 x 710 mm
Weight without packaging:	41 kg
Weight with packaging:	60 kg

3) Package Content



Mobile Stand



Electric components



Mounting screws



Manual

4) Installation

The TRIUMPH BOARD Mobile Stand with Electric Lift for LED LCD's is an electric trolley stand suitable for TRIUMPH BOARD 55", 65", 70" and 84" MULTI Touch LED LCD monitors. Use it only with locked wheels and on level floors.



The Mobile Stand with Electric Lift for LED LCD's comes as a pre-assembled model. The pre-assembled version has the top case with pre-installed motors on the mounting head and the bottom part pre-assembled wheels on the wheel frame.

4.1) Lift column installation

Install the 2 legs with corresponding holes and bolts to the wheel frame.

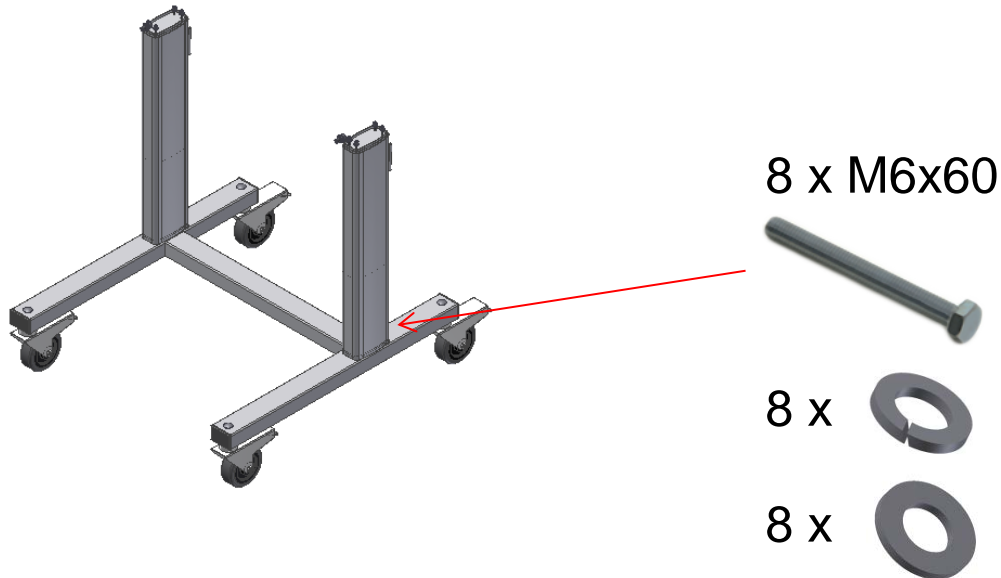

4.2) Mounting head installation

Install the top cabinet on top of the columns with corresponding bolts.

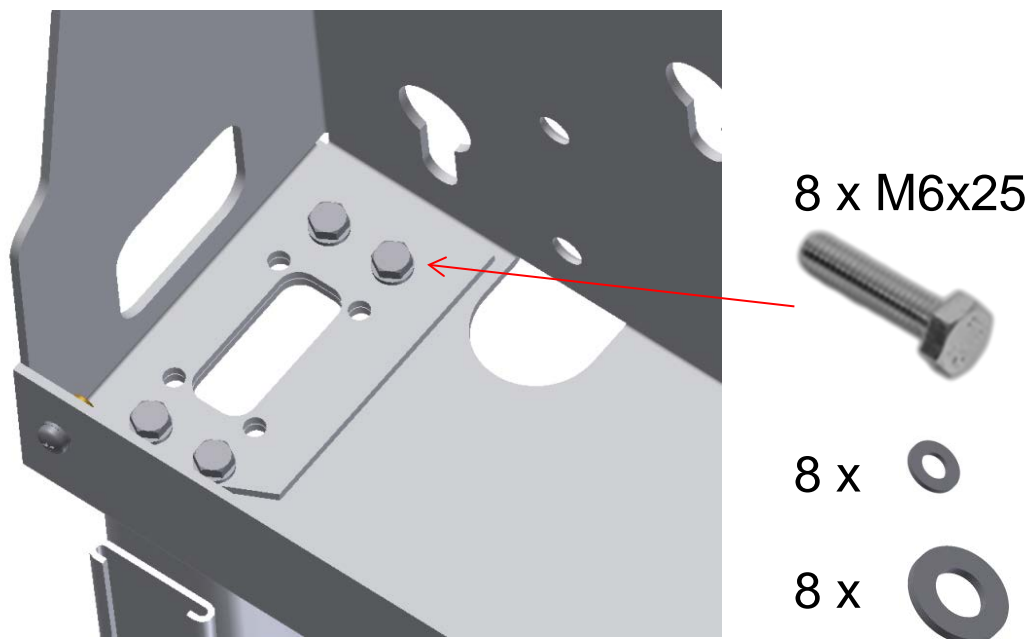

4.3) Power supply installation

Guide the motor cables from columns and switch to the power supply and connect them.
Connect AC cable to the power supply.

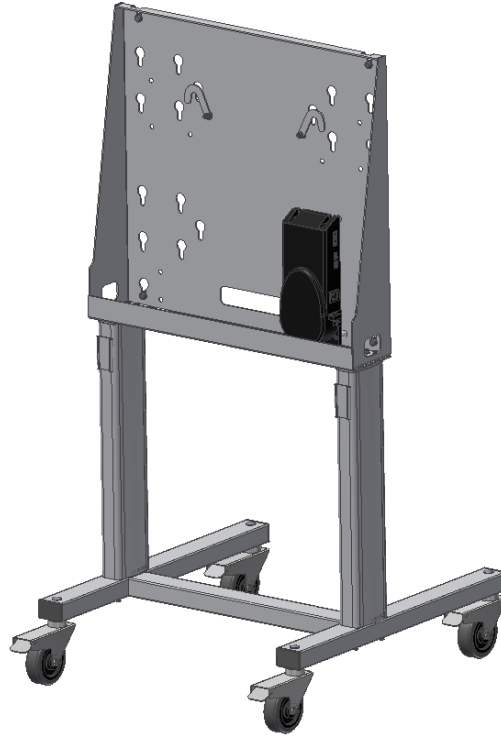

TRIUMPH BOARD Mobile Stand with Electric Lift for LED LCD's has a build-on equipment cabinet that allows installing small equipment behind the screen such as computers and players.

4.4) Screen installation

Install the screen with a universal mounting bracket when the screen is not equipped with a standard VESA mounting interface.
TRIUMPH BOARD Mobile Stand with Electric Lift for LED LCD's has standard the following mounting patterns:

- VESA
400x200
- 65" VESA
600x400
- VESA
600x200
- VESA
300x300
- 55"&70"
VESA
400x400
- 84" VESA
600x600

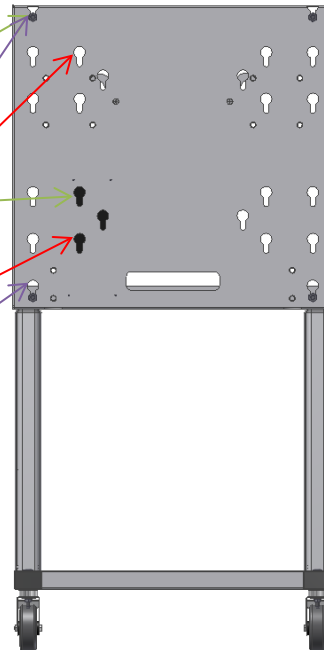

Max. 130 kg!

* VESA mounting pattern may vary between models

Install the screws with washers and countersink cams in the rear of the screen and insert the screen in the cams.

For 55" and 70" MULTI Touch LED LCD use screws M8 x 50mm and for 65" and 84" MULTI Touch LED LCD use screws M8 x 80mm.



Secure it by locking the security hook on the inside.

4.5) Pen tray Installation (Optional)

Install the optional pen tray by using screws and squared nuts as on the pictures below.

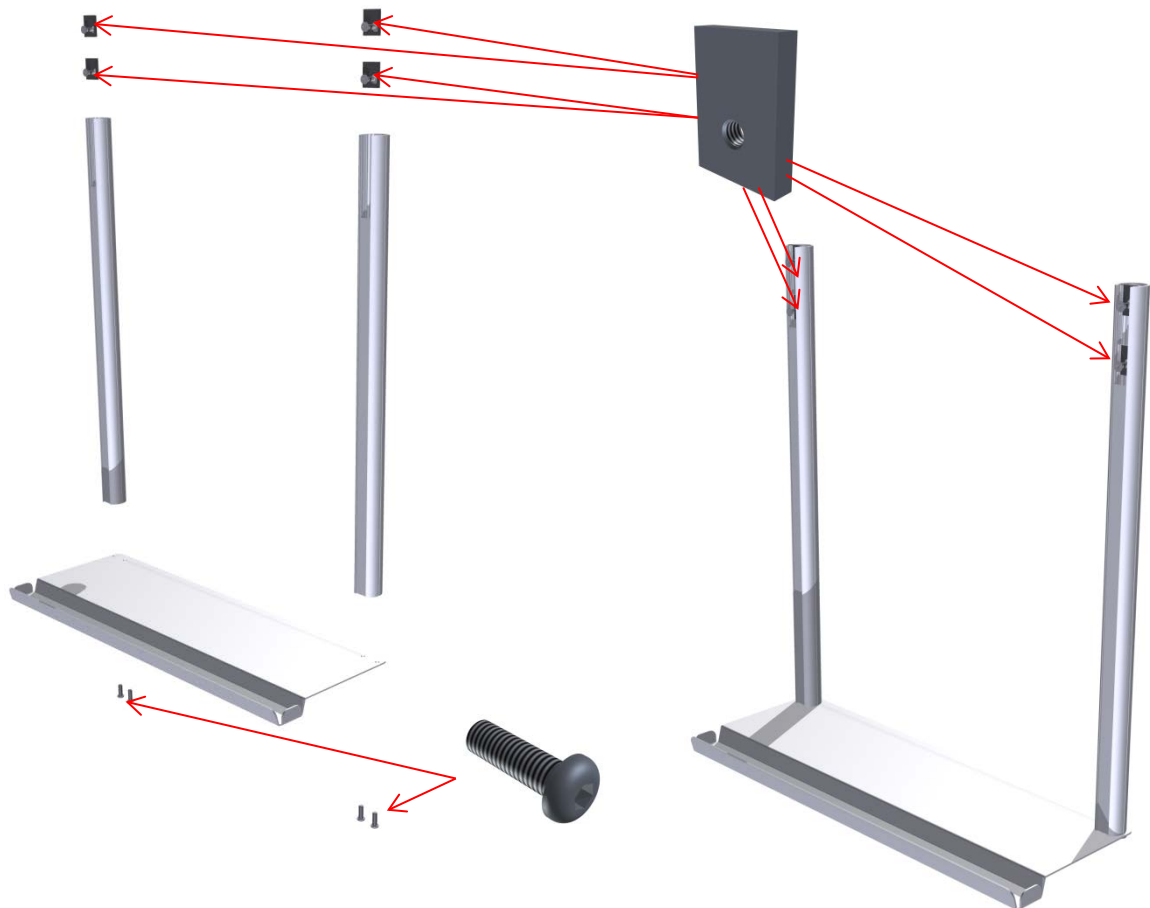

Insert the 2 aluminum rods through the inside of the cabinet of TRIUMPH BOARD Mobile Stand with Electric Lift for LED LCD's.



4.6) Laptop tray installation (Optional)

Install the optional pen tray by using screws as on the pictures below.

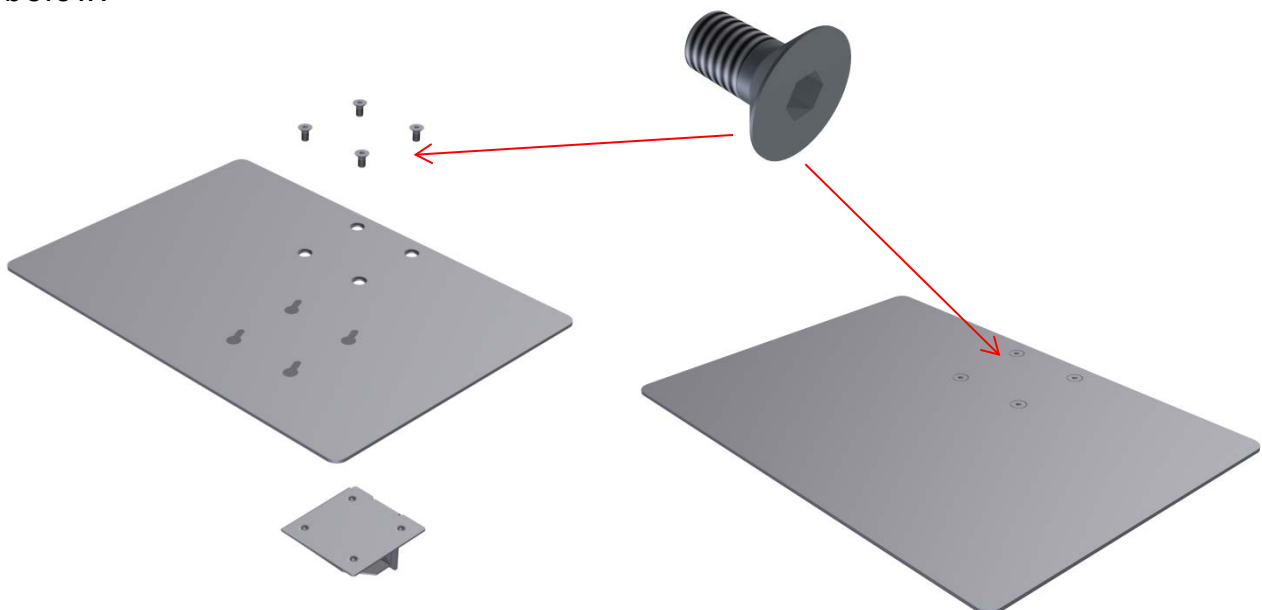

Put the bottom part of Laptop tray on the one of the legs of TRIUMPH BOARD Mobile Stand with Electric Lift for LED LCD's.



4.7) Put back cover on and secure using screws.



5) Repair Service and Contacts

Please contact your local supplier for the warranty and technical service or find all warranty conditions and service partners on our website www.triumphboard.com .
For any questions please email us to info@triumphboard.com

TRIUMPH BOARD a.s.

Neklanova 122/15

128 00 Praha 2

Czech Republic

EU

Phone: +420 224 910 221

Fax: +420 224 910 218

E-mail: info@triumphboard.com

www.triumphboard.com

Notices

Every effort has been made to ensure all information contained in this user guide is correct, but the accuracy or completeness is not guaranteed. Before using this product, you must evaluate it and determine if it is suitable for your intended application. You assume all risks and liability associated with such use. Any statements related to this product which is not contained in this manual or any contrary statements contained on your purchase order shall have no force of effect unless expressly agreed upon, in writing, by this company.

Without this company permission, reproduction or reprinting this user guide or any part is prohibited.