

# TRIUMPH BOARD®

## MOUNTING INSTRUCTIONS FOR ULTRA SHORT PROJECTOR MOUNT

Model: PROJECTOR WALL MOUNT 2000/3000 Series

Max. Weight Loading: 15Kgs

- read these instructions carefully before installing your equipment.
- install the mount in a suitable location using fixings which are appropriate for the wall material and structure. Consult a qualified builder if you are in any doubt as to the structural integrity of the wall.
- use all available fixing points.
- do not attempt to alter or modify any part of the wall mount or its attachments.
- do not use if any parts are broken or appear to be damaged.
- tighten all bolts and fixings securely. Only use fixings provided with this bracket.
- do not mount your projector near to sources of heat or moisture.
- always have a minimum of two persons to install the projector and the mount.

### Mount Assembly Kit



Cable protection grommet

x2

### Projector Fixing Kit



A - M3 x 10mm E - M3 x 25mm

B - M4 x 10mm F - M4 x 25mm

C - M5 x 10mm G - M5 x 25mm

D - M6 x 10mm H - M6 x 25mm

x4



I - M3 Washer K - M5 Washer

J - M4 Washer L - M6 Washer

x4



M - M5 x 10mm

N - M5 x 5mm

O - M6 x 15mm

x4



P - Extension Arm

x4



Q - M5 x 10mm

x4

Also Required



# 1

### Attach Wall Plate To Wall

- For ease of installation mount bracket on wall using position 1 and mark other positions using a spirit level. Then remove fixing from position 1, remove bracket and drill other positions.
- Use Fixings suitable for your type of wall construction.
- Use All available fixing points.
- If in any doubt of the suitability of the wall, it's construction or what type of fixings to use, consult a qualified builder or installer.

#### NOTE:

- For mounting TRIUMPH BOARD PROJECTOR PJ2000/3000 UST DLP projectors locate the wall plate centrally to the screen centre.

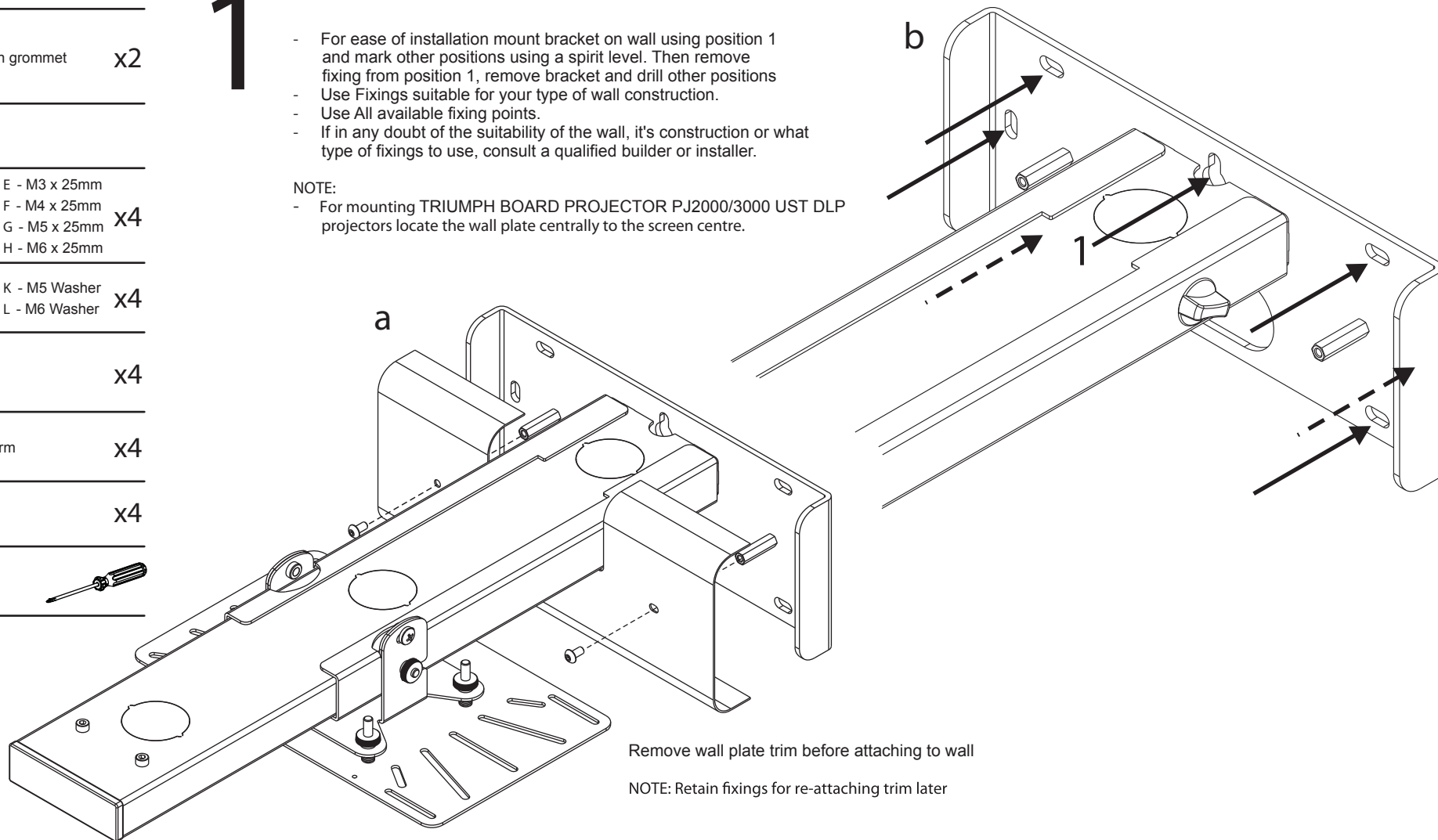

Remove wall plate trim before attaching to wall

NOTE: Retain fixings for re-attaching trim later

# 3

Attach TRIUMPH BOARD PROJECTOR PJ2000/3000 UST DLP

a

Remove interface plate by removing screws 'b' (x2) and loosening thumbwheels 'a' (x2). Then you can un-hook the plate.

NOTE: Retain screws 'b' for use later

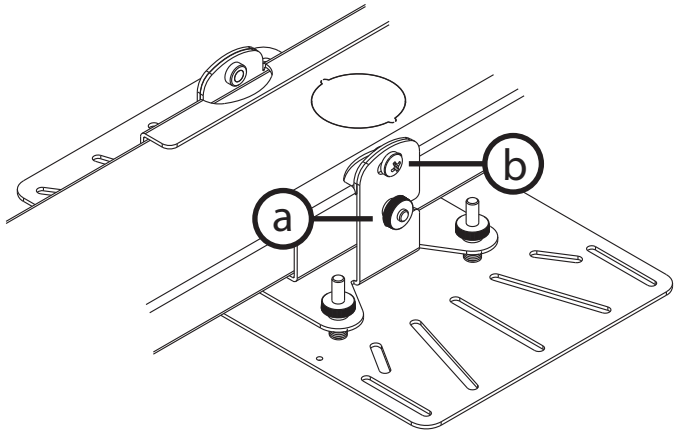

b

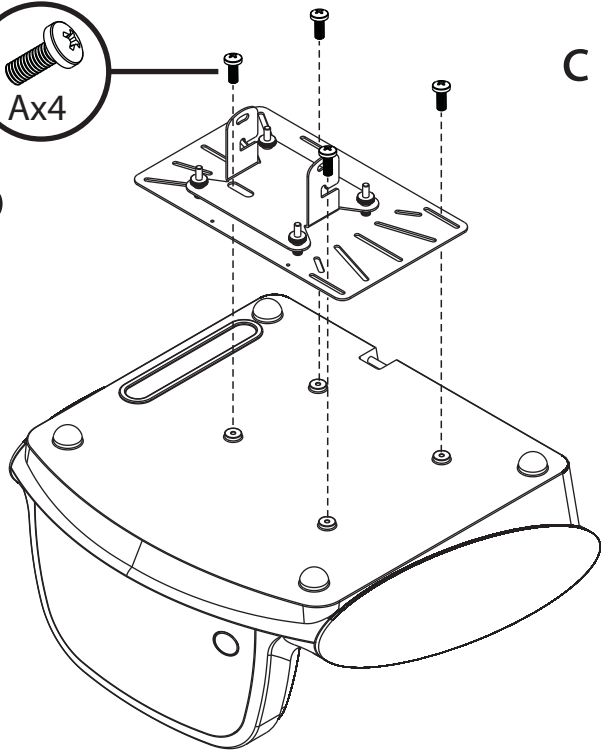

c

Re-attach interface plate by hooking on to support. To secure plate, follow reverse of stage 3a.

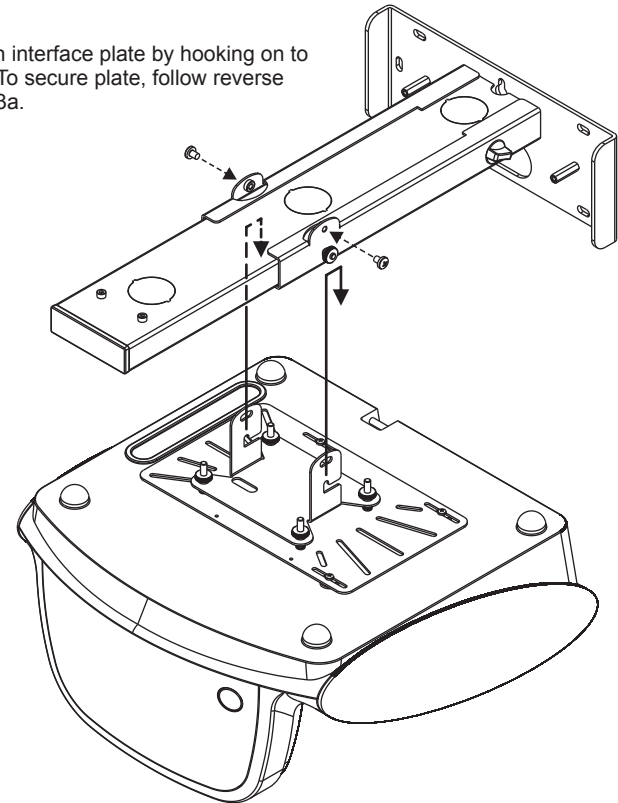

# 4

Attaching Third Party Projectors

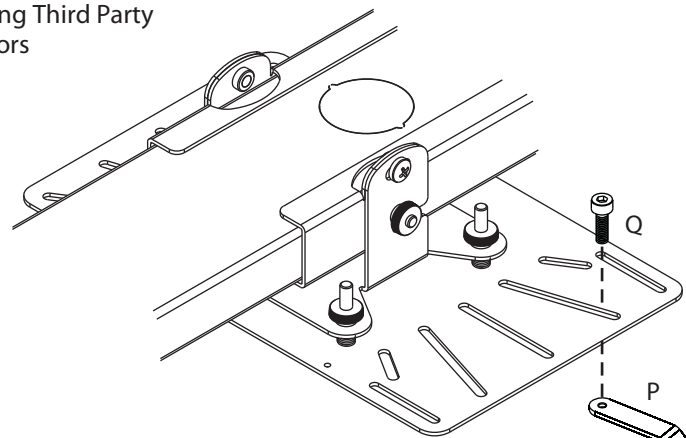

NOTE:

Use universal fixing kit as demonstrated right using bolts, extension arms and/or spacers to attach to third party projector models. Use relevant fixings in all available fixing points on projector. Any slots or holes in the interface plate can be used depending on required position of extension arms.

To Projector

# 5

Adjust length

Projector removed in this view for clarity

Loosen hand wheels 'a' (x2). Slide projector to desired position and re-tighten hand wheels.

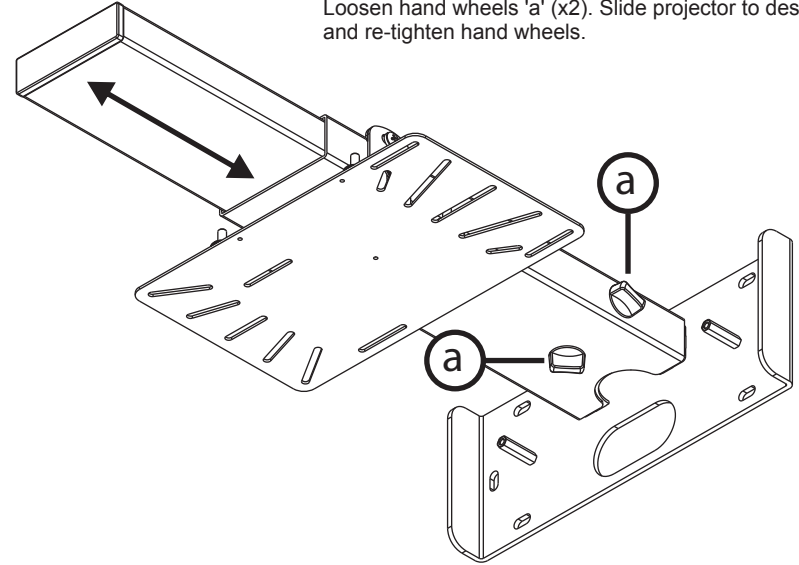

# 6 Cable Routing

Projector removed in this view for clarity

**a** Entry option through wall plate and in to support

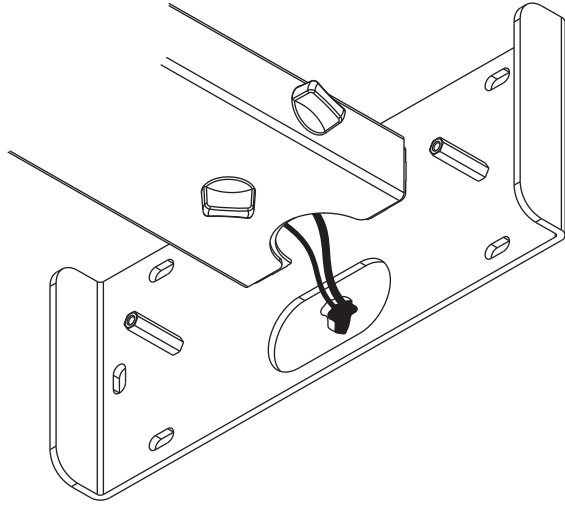

**b** Entry option bypassing wall plate and in to support

i. Remove knock-out to reveal access hole

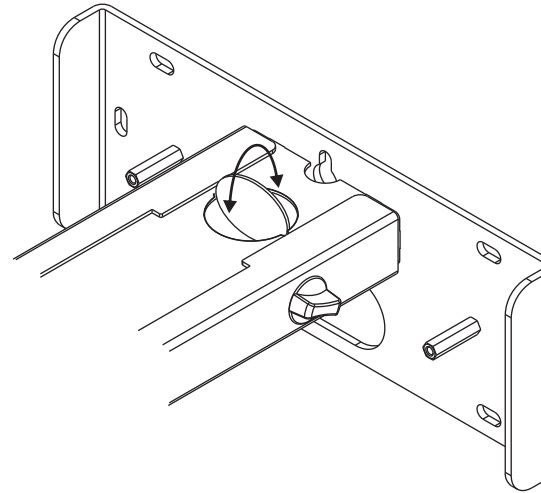

i. Insert Cable Protection Grommet and feed Cables in to support.

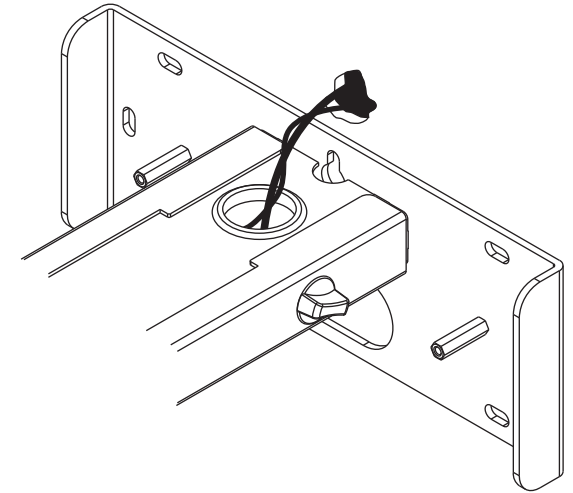

**C** Cable exit from mount to projector

Remove knock-out nearest to desired exit point depending on position of projector. To remove knock-out follow Stage '6b'. Route cable out of support and through cable protection grommet. Secure cable protection grommet into knock-out hole before adjusting cables.

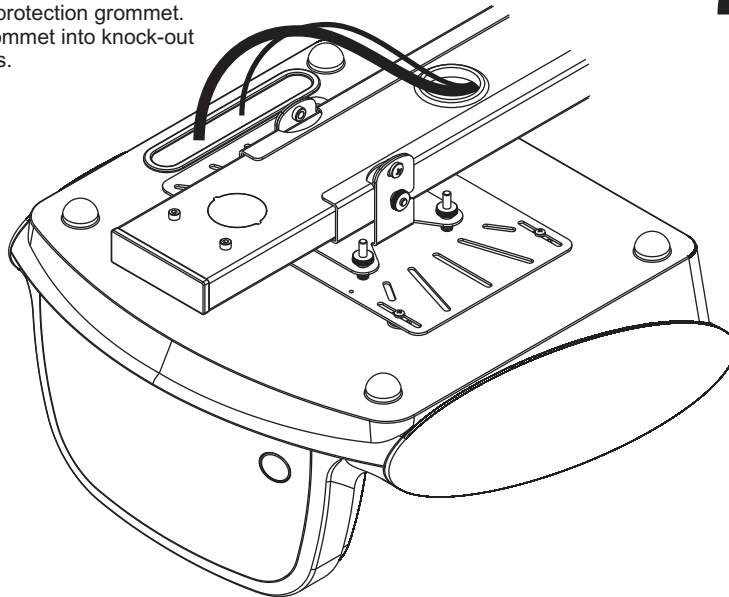

# 7 Fine Adjustment

- Tilt - Loosen bolt 'a' (x2). Adjust projector to required angle. Re-tighten bolt 'a' (x2).
- Fine level - Adjust thumbwheels 'b' independently to achieve desired level.
- Lateral Positioning - Loosen Projector fixing screws slightly and slide the projector until image is centralised to screen.

**NOTE: Do not fully remove any of the adjustment wheels or fixings described above**

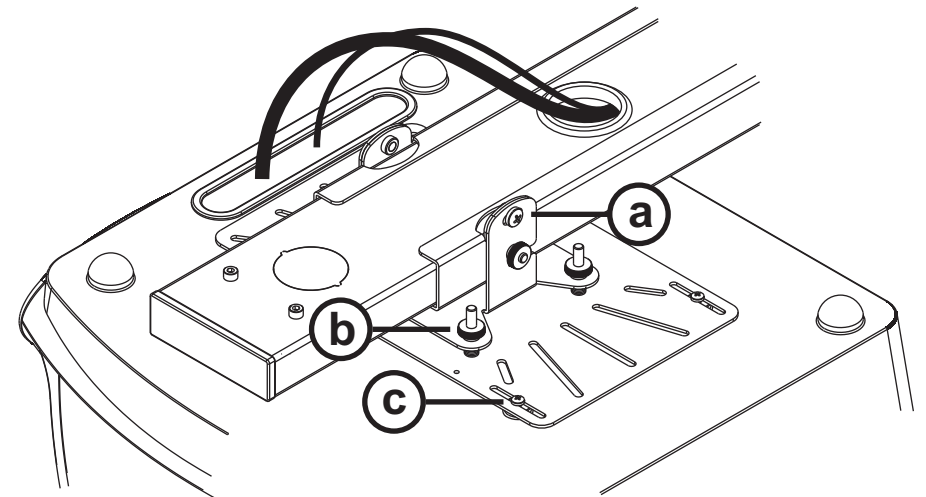



Re-attach Wall Plate Trim  
Projector removed in this view for clarity

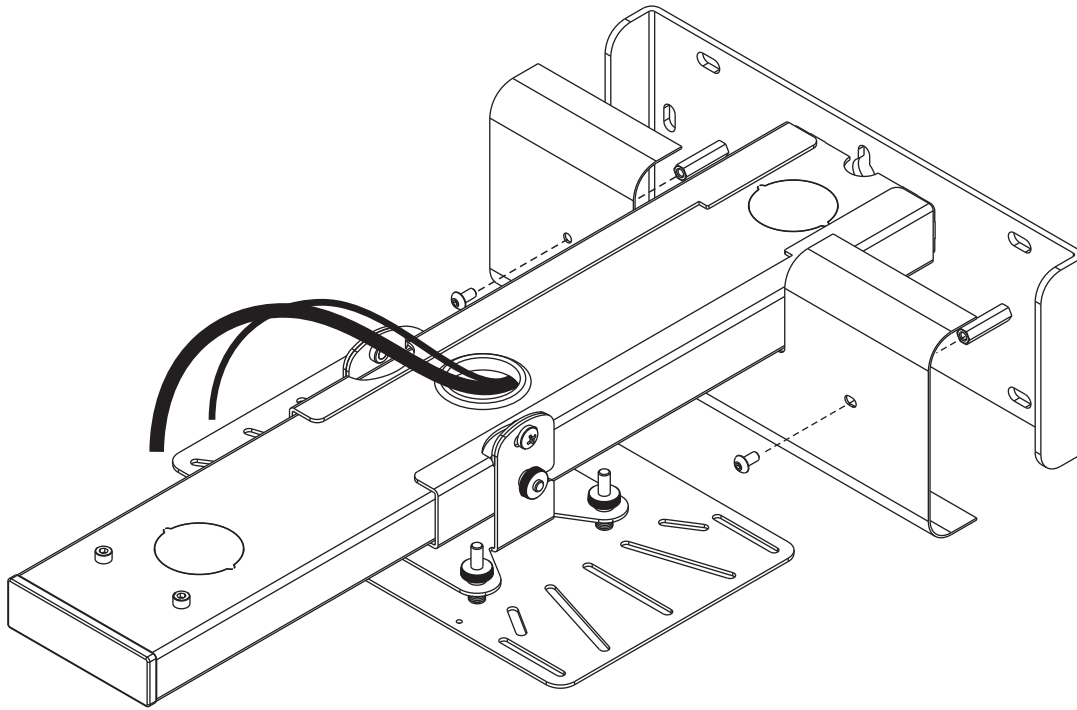

- read these instructions carefully before installing your equipment.
- install the mount in a suitable location using fixings which are appropriate for the wall material and structure. Consult a qualified builder if you are in any doubt as to the structural integrity of the wall.
- use all available fixing points.
- do not attempt to alter or modify any part of the wall mount or it's attachments.
- do not use if any parts are broken or appear to be damaged.
- tighten all bolts and fixings securely. Only use fixings provided with this bracket.
- do not mount your projector near to sources of heat or moisture.
- always have a minimum of two persons to install the projector and the mount.

# TRIUMPH BOARD®

## ULTRA SHORT THROW PROJECTOR MOUNT

MODEL: PROJECTOR WALL MOUNT 2000/3000 series

Max Weight Loading: 15Kgs

### Specifications;

Throw distance - TRIUMPH BOARD PROJECTOR PJ2000/3000 UST DLP  
350mm to 775mm (From wall to lens)  
UNIVERSAL (Approx dependent on fixing positions)  
0mm to 850mm

Adjustment - 425mm Throw Adjustment  
+/- 5° Tilt Adjustment  
4-point vernier adjustment tilt and yaw  
20mm left/right lateral adjustment!

Compatibility - TRIUMPH BOARD  
PJ 2000/3000 UST DLP

Optoma  
XGA & WXGA Ultra Short Throw Projectors  
OPTOMA XGA & WXGA Short Throw Projectors\*  
Hitachi  
ED-D10N, ED-D11N, CP-D10  
ED-A100\*, ED-A101\*, ED-A111\*, CP-A100\*, ED-A220  
NEC  
M2XXXX, M3XXXX  
U2XX, U3XX

Compatibility information provided as a guide. Please check with the manufacturer to ensure 100% compatibility.

\*Screen size limited